

# T2 2:1 Ratio Transfer Pump

311882D

***For use with polyurethane foam, polyurea, and similar non-flammable materials. Not for use in explosive atmospheres.***

## **Model 295616 (55-gallon drum)**

*180 psi (1.2 MPa, 12 bar) Maximum Air Working Pressure  
405 psi (2.7 MPa, 27 bar) Maximum Fluid Working Pressure*

## **Model 261058 (15-gallon drum)**

*180 psi (1.2 MPa, 12 bar) Maximum Air Working Pressure  
405 psi (2.7 MPa, 27 bar) Maximum Fluid Working Pressure*



### **Important Safety Instructions**

Read all warnings and instructions in this manual.  
Save these instructions.

This manual is available in the following languages.

311882	English
312524	French
312525	German
312526	Italian
312527	Russian
312528	Spanish
312529	Swedish
312530	Chinese
312531	Korean
312532	Japanese

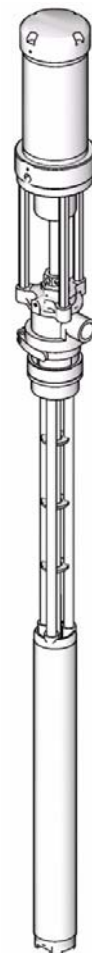



ti9889a

# Contents

<b>Warnings</b> .....	<b>2</b>	<b>Air Motor Repair</b> .....	<b>11</b>
<b>Typical Installation</b> .....	<b>4</b>	<b>Pump Lower Repair</b> .....	<b>12</b>
<b>Moisture Sensitivity of Isocyanates</b> .....	<b>7</b>	<b>Reassembly</b> .....	<b>15</b>
Isocyanate Hazard .....	7	<b>Troubleshooting</b> .....	<b>15</b>
Foam Self-Ignition .....	7	<b>Parts - Model 295616</b> .....	<b>16</b>
Keep Components A and B Separate .....	7	<b>Parts - Model 261058</b> .....	<b>18</b>
Changing Materials .....	7	<b>Technical Data</b> .....	<b>20</b>
<b>Setup</b> .....	<b>8</b>	Dimensions .....	20
Grounding the System .....	9	Performance Chart .....	21
<b>Operation</b> .....	<b>10</b>	<b>Graco Standard Warranty</b> .....	<b>22</b>
Pressure Relief Procedure .....	10	<b>Graco Information</b> .....	<b>22</b>
Flushing .....	10		
Daily Startup .....	10		
Daily Shutdown .....	10		

# Warnings

The following warnings are for the setup, use, grounding, maintenance, and repair of this equipment. The exclamation point symbol alerts you to a general warning and the hazard symbol refers to procedure-specific risk. Refer back to these warnings. Additional, product-specific warnings may be found throughout the body of this manual where applicable.

 <b>WARNING</b>	
	<p><b>TOXIC FLUID OR FUMES HAZARD</b></p> <p>Toxic fluids or fumes can cause serious injury or death if splashed in the eyes or on skin, inhaled, or swallowed.</p> <ul style="list-style-type: none"> <li>• Read MSDS's to know the specific hazards of the fluids you are using.</li> <li>• Store hazardous fluid in approved containers, and dispose of it according to applicable guidelines.</li> <li>• Always wear impervious gloves when spraying or cleaning equipment.</li> </ul>
	<p><b>PERSONAL PROTECTIVE EQUIPMENT</b></p> <p>You must wear appropriate protective equipment when operating, servicing, or when in the operating area of the equipment to help protect you from serious injury, including eye injury, inhalation of toxic fumes, burns, and hearing loss. This equipment includes but is not limited to:</p> <ul style="list-style-type: none"> <li>• Protective eyewear</li> <li>• Clothing and respirator as recommended by the fluid and solvent manufacturer</li> <li>• Gloves</li> <li>• Hearing protection</li> </ul>

**WARNING**
**EQUIPMENT MISUSE HAZARD**

Misuse can cause death or serious injury.

- Do not operate the unit when fatigued or under the influence of drugs or alcohol.
- Do not exceed the maximum working pressure or temperature rating of the lowest rated system component. See **Technical Data** in all equipment manuals.
- Use fluids and solvents that are compatible with equipment wetted parts. See **Technical Data** in all equipment manuals. Read fluid and solvent manufacturer's warnings. For complete information about your material, request MSDS forms from distributor or retailer.
- Check equipment daily. Repair or replace worn or damaged parts immediately with genuine manufacturer's replacement parts only.
- Do not alter or modify equipment.
- Use equipment only for its intended purpose. Call your distributor for information.
- Route hoses and cables away from traffic areas, sharp edges, moving parts, and hot surfaces.
- Do not kink or over bend hoses or use hoses to pull equipment.
- Keep children and animals away from work area.
- Comply with all applicable safety regulations.

**PRESSURIZED EQUIPMENT HAZARD**

Fluid from the gun/dispense valve, leaks, or ruptured components can splash in the eyes or on skin and cause serious injury.

- Follow **Pressure Relief Procedure** in this manual, when you stop spraying and before cleaning, checking, or servicing equipment.
- Tighten all fluid connections before operating the equipment.
- Check hoses, tubes, and couplings daily. Replace worn or damaged parts immediately.

**MOVING PARTS HAZARD**

Moving parts can pinch or amputate fingers and other body parts.

- Keep clear of moving parts.
- Do not operate equipment with protective guards or covers removed.
- Pressurized equipment can start without warning. Before checking, moving, or servicing equipment, follow the **Pressure Relief Procedure** in this manual. Disconnect power or air supply.

# Typical Installation

## Typical Installation, without Circulation

### Key for FIG. 1

- |   |  |   |                                  |
|---|--|---|----------------------------------|
| A | Reactor Proportioner                                 | H | Waste Containers                 |
| B | Heated Hose  | J | Fluid Supply Lines (217382)      |
| C | Fluid Temperature Sensor (FTS)                       | K | Feed Pumps                       |
| D | Heated Whip Hose                                     | L | Agitator                         |
| E | Fusion Spray Gun                                     | M | Desiccant Dryer                  |
| F | Proportioner and Gun Air Supply Hose                 | N | Bleed Lines/Over Pressure Relief |
| G | Feed Pump Air Supply Lines (3/8 in. (76 mm) ID min.) | P | Gun Fluid Manifold               |

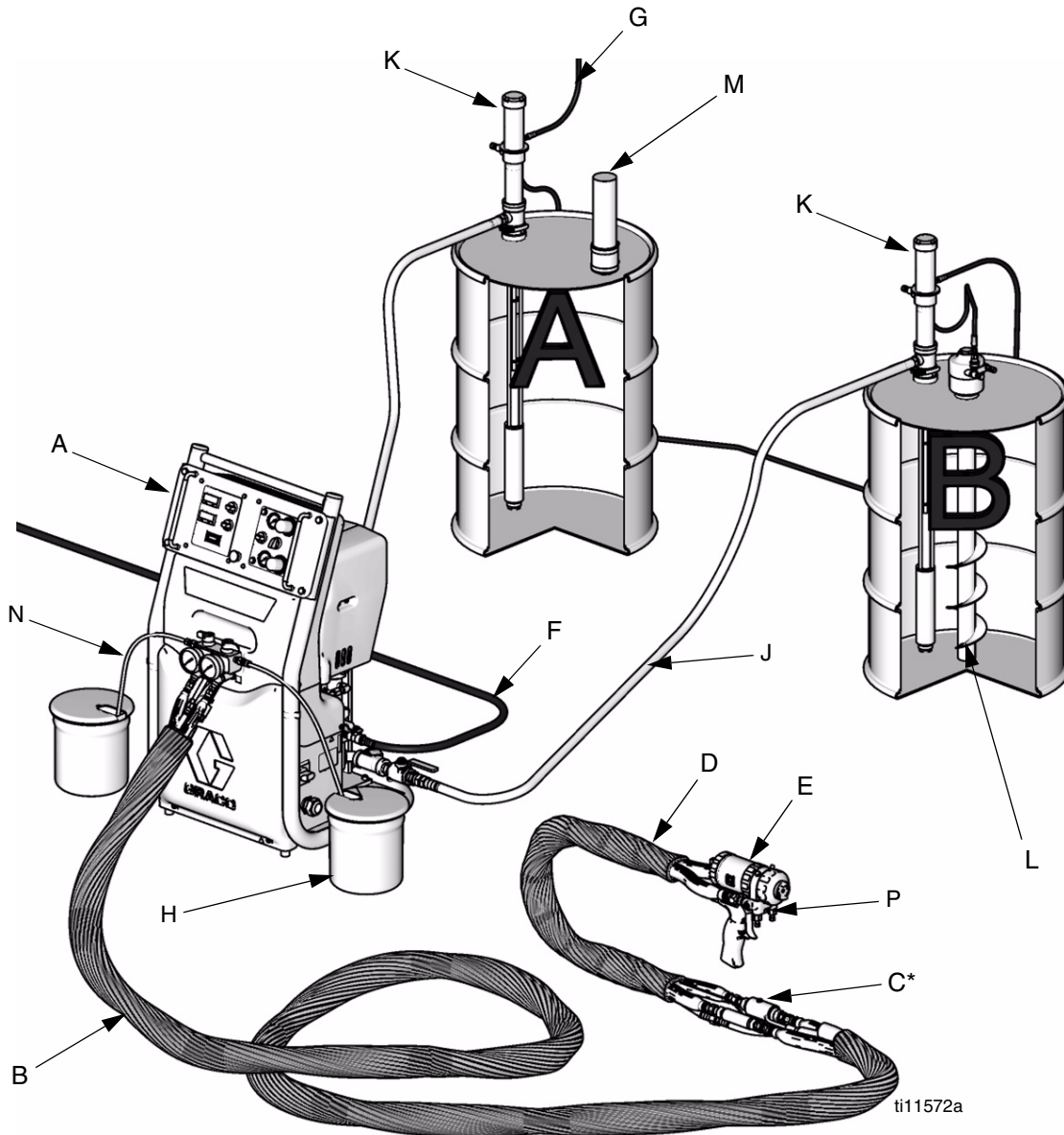

\* Shown exposed for clarity. Wrap with tape during operation.

FIG. 1: Typical Installation, without Circulation

## Typical Installation, with Circulation

### Key for FIG. 2

- |   |                                      |   |   |
|---|--------------------------------------|---|---|
| A | Reactor Proportioner                 | G | Feed Pump Air Supply Lines (3/8 in. (76 mm) ID min) |
| B | Heated Hose                          | J | Fluid Supply Lines                                  |
| C | Fluid Temperature Sensor (FTS)       | K | Feed Pumps  |
| D | Heated Whip Hose                     | L | Agitator  |
| E | Fusion Spray Gun                     | M | Desiccant Dryer                                     |
| F | Proportioner and Gun Air Supply Hose | N | Recirculation/Over Pressure Relief Return Hoses     |
|   |                                      | P | Gun Fluid Manifold                                  |

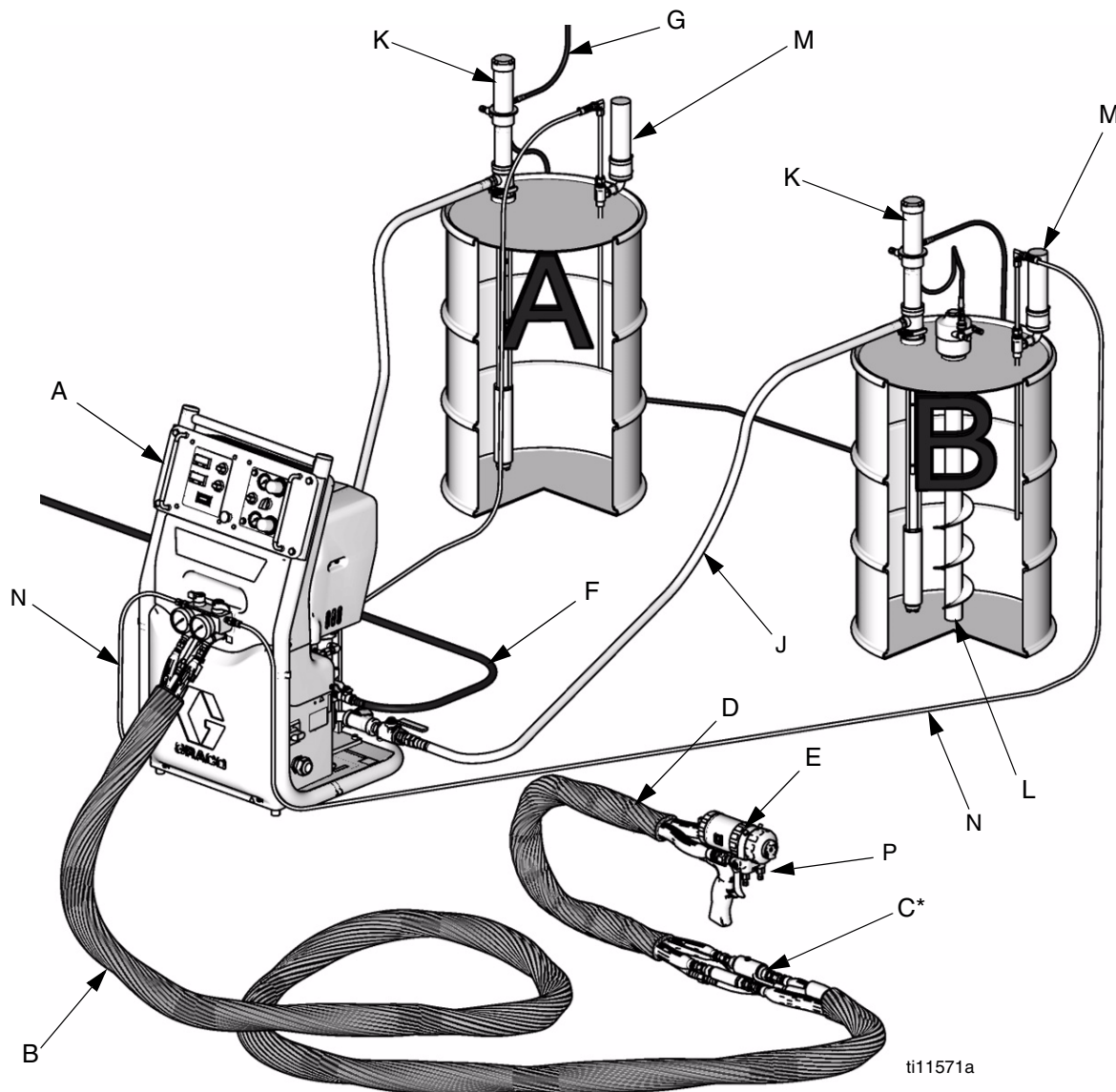

\* Shown exposed for clarity. Wrap with tape during operation.

FIG. 2: Typical Installation, with Circulation

## Typical Installation for Lubrication Applications

### Key for FIG. 3

- |   |  |   |                              |
|---|--|---|------------------------------|
| A | Pump Air Regulator                               | G | Grounded Air Hose            |
| B | Air Line Lubricator                              | H | Grounded Fluid Hose          |
| C | Air Line Filter                                  | J | Pump Fluid Inlet             |
| D | Bleed-Type Master Air Valve (required, for pump) | K | 1/4 npt(f) Pump Air Inlet    |
| E | Fluid Drain Valve (required)                     | L | 1/2 npt(f) Pump Fluid Outlet |
| F | Bung Adapter                                     |   |                              |

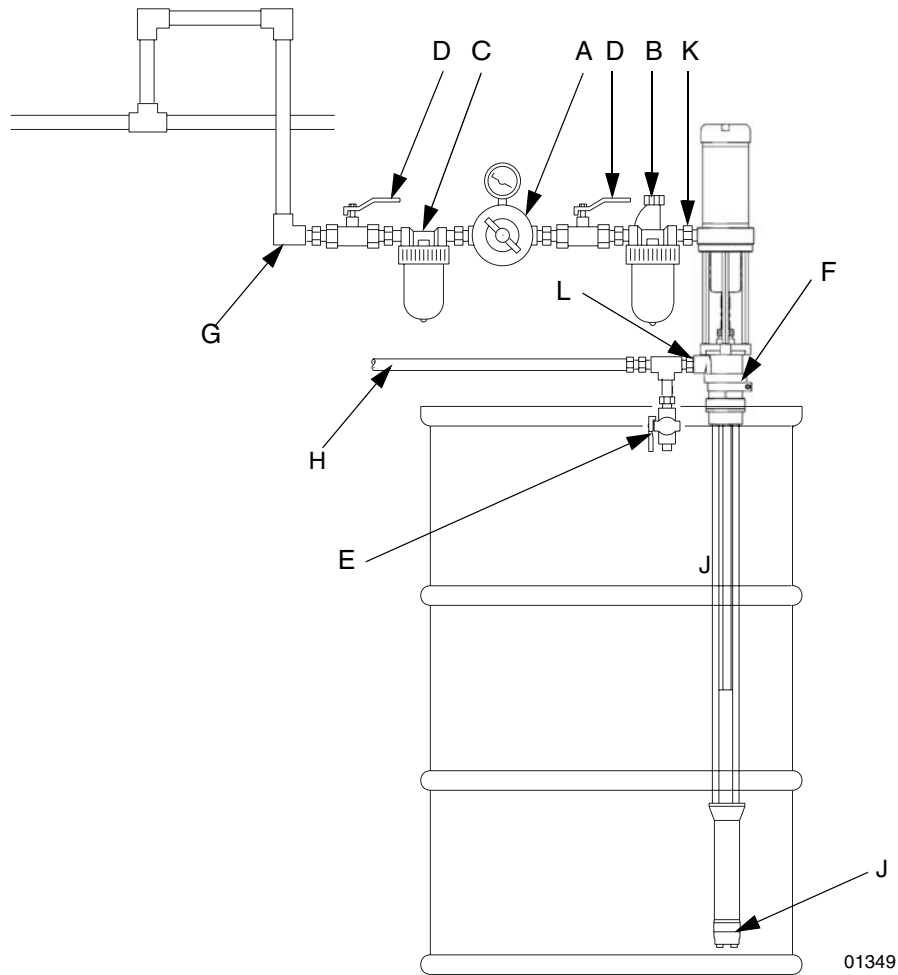



FIG. 3: Typical Installation for Lubrication Applications

# Moisture Sensitivity of Isocyanates





Isocyanates (ISO) are catalysts used in two component foam and polyurea coatings. ISO will react with moisture (such as humidity) to form small, hard, abrasive crystals, which become suspended in the fluid. Eventually a film will form on the surface and the ISO will begin to gel, increasing in viscosity. If used, this partially cured ISO will reduce performance and the life of all wetted parts.

 The amount of film formation and rate of crystallization varies depending on the blend of ISO, the humidity, and the temperature.



To prevent exposing ISO to moisture:

- Always use a sealed container with a desiccant dryer in the vent, or a nitrogen atmosphere. **Never** store ISO in an open container.
- Use moisture-proof hoses specifically designed for ISO, such as those supplied with your system.
- Never use reclaimed solvents, which may contain moisture. Always keep solvent containers closed when not in use.
- Never use solvent on one side if it has been contaminated from the other side.
- Always lubricate threaded parts with Part 217374 ISO pump oil or grease when reassembling.

## Isocyanate Hazard

						
Read material manufacturer's warnings and material MSDS to know the specific hazards of isocyanates. Use equipment in a well-ventilated area. Wear respirator, gloves, and protective clothing when using isocyanates.						

## Foam Self-Ignition

						
Some materials may become self-igniting if applied too thick. Read material manufacturer's warnings and material MSDS.						

## Keep Components A and B Separate

<b>CAUTION</b>
To prevent cross-contamination of the equipment's wetted parts, <b>never</b> interchange component A and component B.

## Changing Materials

- When changing materials, flush the equipment multiple times to ensure it is thoroughly clean.
- Check with your material manufacturer for chemical compatibility.
- Some materials use catalyst on the A side, but some applications may use catalyst on the B side.
- Epoxies often have amines on the B (catalyst) side. Polyurethanes often have amines on the B (resin) side.

# Setup

1. Apply thread sealant to the male threads of the air needle valve (48) and the quick disconnect fitting (49) and install. See FIG. 4

⚠ Apply thread sealant

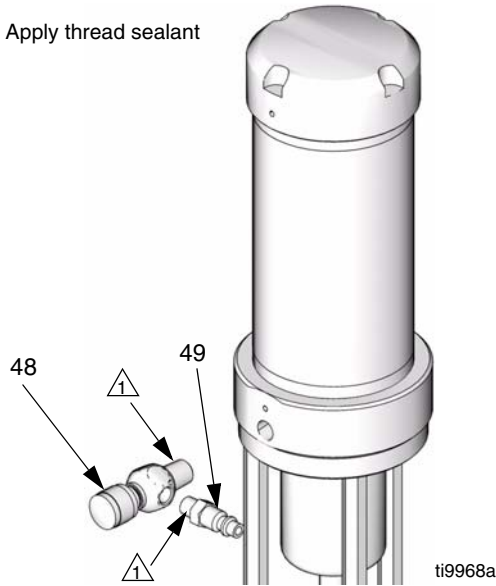

FIG. 4

2. Apply thread sealant to the male outlet fitting (not supplied) and insert into the outlet port. See FIG. 5.

⚠ Apply thread sealant

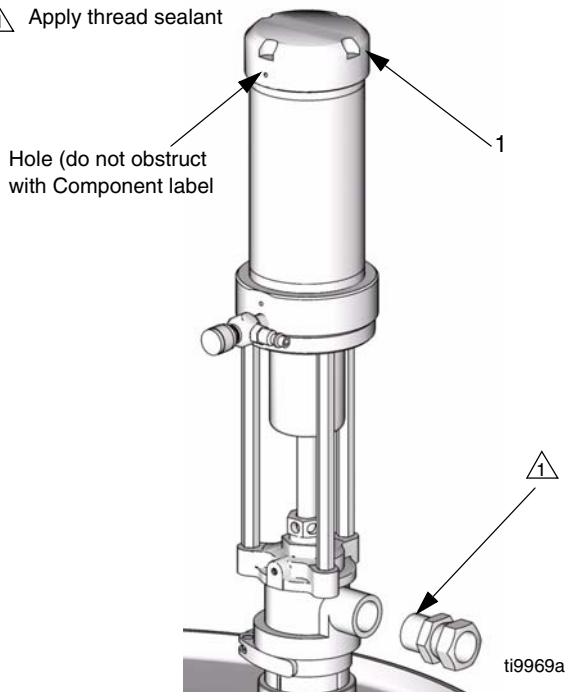

FIG. 5

3. Use labels (70) provided to identify the appropriate pump for your material. See FIG. 5 and FIG. 6. When applying component labels (70) to pump cap (1) make sure you do not cover the hole in the cap.

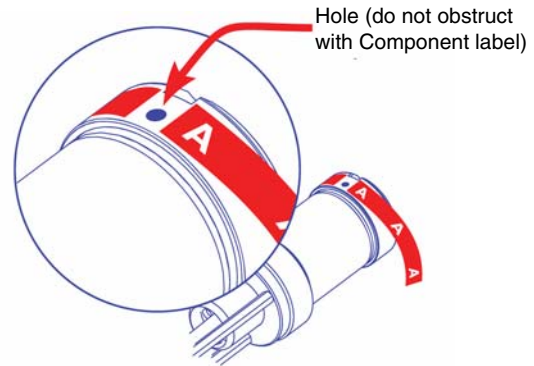

FIG. 6

4. Lubricate the bung adapter inside diameter and mounting threads. Ensure the gasket is in place and screw the bung adapter (51) securely into the bung-hole of the drum. Insert the pump through the adapter and lock it in place. See FIG. 7.

⚠ Lubricate threads

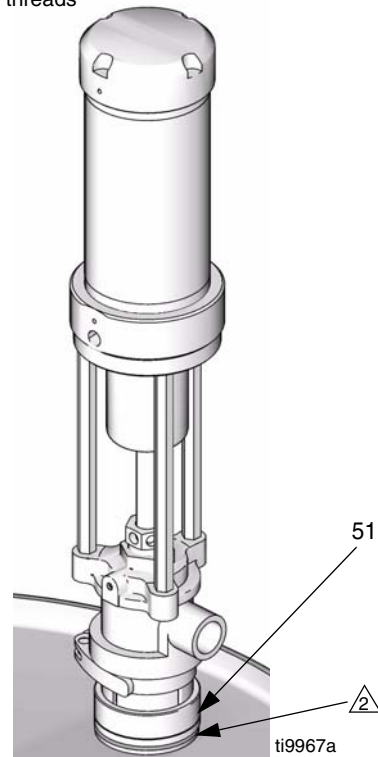

FIG. 7

5. Install air line (3/8 in. (76 mm) ID minimum) with quick disconnect air coupler (52) provided. See FIG. 8.

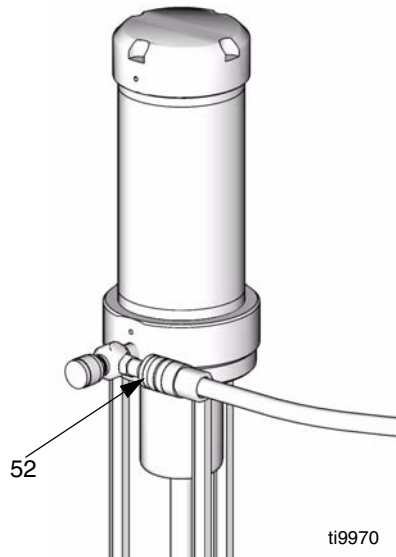
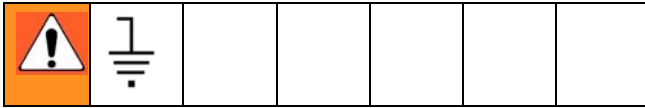

FIG. 8

2. *Air compressor*: according to manufacturer's recommendations.
3. *Fluid hoses*: use only grounded hoses with a maximum of 300 ft (91 m) combined hose length to ensure grounding continuity. Refer to Hose Grounding Continuity.
4. *Dispensing valve*: grounding is obtained through connection to a properly grounded fluid hose and pump.
5. *Object being sprayed*: according to local code.
6. *Fluid supply container*: according to local code.
7. *All solvent pails used when flushing*, according to local code. Use only metal pails, which are conductive. Do not place the pail on a non-conductive surface, such as paper or cardboard, which interrupts the grounding continuity.
8. *To maintain grounding continuity when flushing or relieving pressure*, always hold a metal part of the spray gun/dispensing valve firmly to the side of a grounded *metal* pail, then trigger the gun/valve.

## Grounding the System



To reduce the risk of static sparking, ground the pump and all other equipment used or located in the pumping area. Check your local electrical code for detailed grounding instructions for your area and type of equipment. **Ground all of this equipment.**

1. *Pump*: Connect Ground Wire (Y) to grounding screw (72) and tighten the screw securely. See FIG. 9. Connect the other end of the wire to a true earth ground. Make certain to comply with all National, State, and Local Electrical Codes.

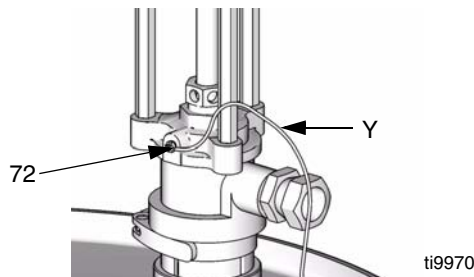



FIG. 9



# Operation

## Pressure Relief Procedure

						
Trapped air can cause the pump to cycle unexpectedly, which could result in serious injury from splashing or moving parts.						

1. Engage trigger lock.
2. Close the bleed-type master air valve.
3. Disengage the trigger lock.
4. Hold a metal part of the dispense valve firmly to a grounded metal pail. Trigger the valve to relieve pressure.
5. Engage the trigger lock.
6. Open all fluid drain valves in the system, having a waste container ready to catch drainage. Leave drain valve(s) open until you are ready to dispense again.
7. If you suspect the nozzle or hose is clogged or that pressure has not been fully relieved after following the steps above, VERY SLOWLY loosen the hose end coupling to relieve pressure gradually, then loosen completely. Clear hose or nozzle obstruction.

## Flushing

						
Trapped air can cause the pump to cycle unexpectedly, which could result in serious injury from splashing or moving parts.						

- Flush at the lowest pressure possible. Check connectors for leaks and tighten as necessary.
- Flush with a fluid that is compatible with the fluid being dispensed and the equipment wetted parts.

1. Follow **Pressure Relief Procedure**, page 10.
2. Place suction tube in grounded metal drum containing cleaning fluid.
3. Set pump to lowest possible fluid pressure, and start pump.
4. Hold a metal part of the dispense valve firmly to a grounded metal pail. Trigger the dispense valve until clean solvent dispenses.
5. Remove valve from hose.
6. Follow **Pressure Relief Procedure**, and remove fluid filter and soak in solvent. Replace filter cap.

## Daily Startup

1. Verify that the air needle valve is closed.
2. Connect the air line quick disconnect coupler to the transfer pump
3. Turn on the main air supply.
4. Slowly open the air needle valve until the transfer pump runs slowly.
5. Use the air needle valve to control the pump speed.

<b>Caution</b>
Never allow the pump to run dry of the fluid being pumped. A dry pump will quickly accelerate to a high speed and could cause personal injury and/or damage to the pump. If the pump accelerates quickly or starts running too fast, stop it immediately and check the fluid supply. If the supply container is empty or air has been pumped into the lines, refill the container and prime the pump and the lines with fluid, or flush and leave it filled with a compatible solvent. Be sure to eliminate all air from the fluid system.
Do not attempt to operate pump unless it is securely mounted in a drum.

## Daily Shutdown

1. Disconnect air line coupler.
2. When air pressure is bled off, close the air line needle valve.

# Air Motor Repair

1. Remove cap (1), cylinder (4), and square gaskets (3\*). Inspect all parts, including spring under cap (not shown in FIG. 10) for damage and replace if necessary. See FIG. 10. Unscrew by hand or use a chain wrench to prevent distortion of the cylinder's shape.

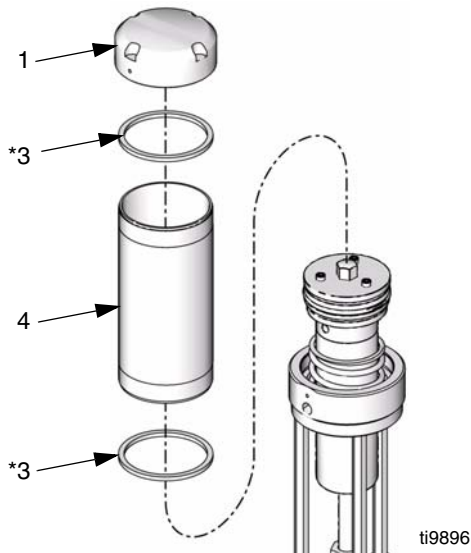

**FIG. 10**

2. Loosen set screw (18) and unscrew air piston head (5). If necessary to assist turning, wedge a screwdriver blade between the screw heads (16) and the hex cap (9). Inspect o-rings (13\* and 15\*) for damage and replace if necessary. During reassembly, do not add thread lock paste to the piston head. Ensure o-ring (13\*) is correctly positioned and not pinched. See FIG. 11.

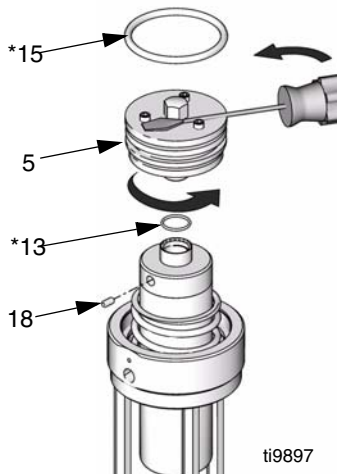

**FIG. 11**

3. Remove 3 screws (16) from top of air piston. Remove valve disk (8) and spacers (11). Remove washer (6\*) from valve disk. Inspect all parts for damage. During reassembly, ensure spacers (11) do not pinch gaskets (10). See FIG. 12.

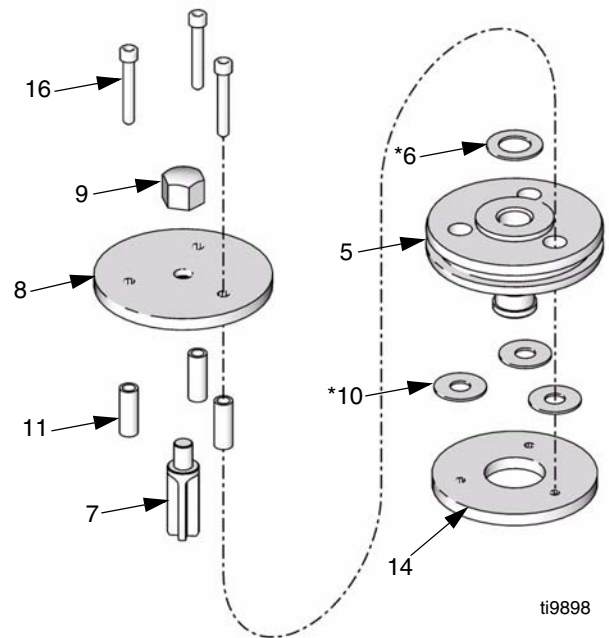

**FIG. 12**

4. Place pin tool (69) in piston hole to prevent piston from turning. Use second pin tool (69) to unscrew piston cap (17) and separate from piston (21) to expose dowel pin (19). See FIG. 13.

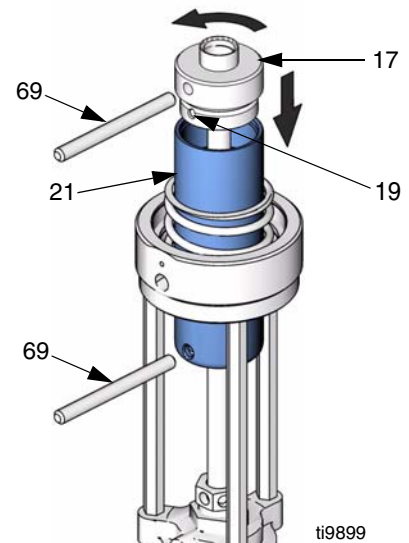

**FIG. 13**

- Remove dowel pin (19) and take piston cap (17) off transfer shaft (20). Remove o-ring (50\*) from piston cap. Inspect all parts for damage. See FIG. 14.

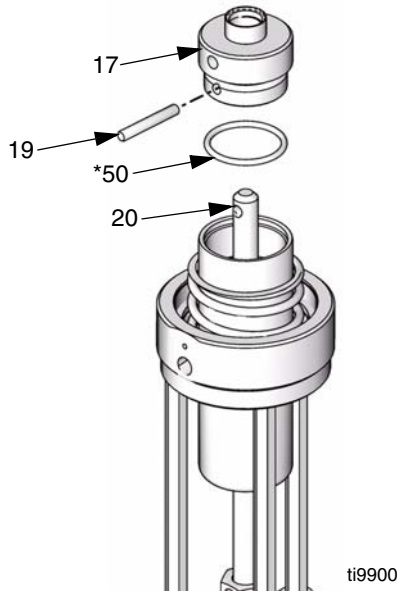

FIG. 14

## Pump Lower Repair

- Use a chain wrench near the top of the suction tube at the point indicated in FIG. 16, and a wrench on the flats of the foot valve (45) to loosen the foot valve from the suction tube (44). To prevent damage to the suction tube, do not remove the foot valve until instructed to do so in step 3.

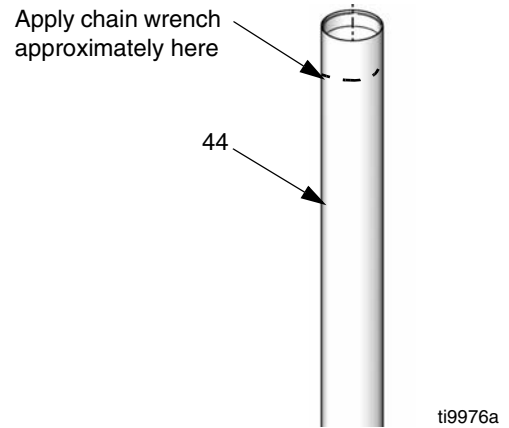

FIG. 16

- Slide air piston (21) out the top of the air motor base (23). Remove o-ring (24\*) from air motor base. Inspect all parts, including the spring (22) in the air motor base, for damage. See FIG. 15.

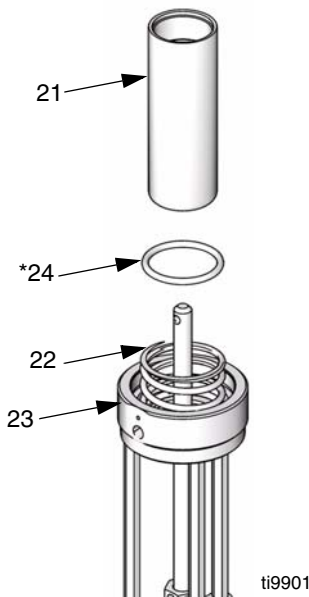



FIG. 15

-  When removing the suction tube, be very careful not to bend, dent, or damage it. To avoid damage, use the chain wrench only at the top and bottom of the suction tube as indicated in FIG. 16 and FIG. 17. Do not apply the wrench to the middle of the suction tube.

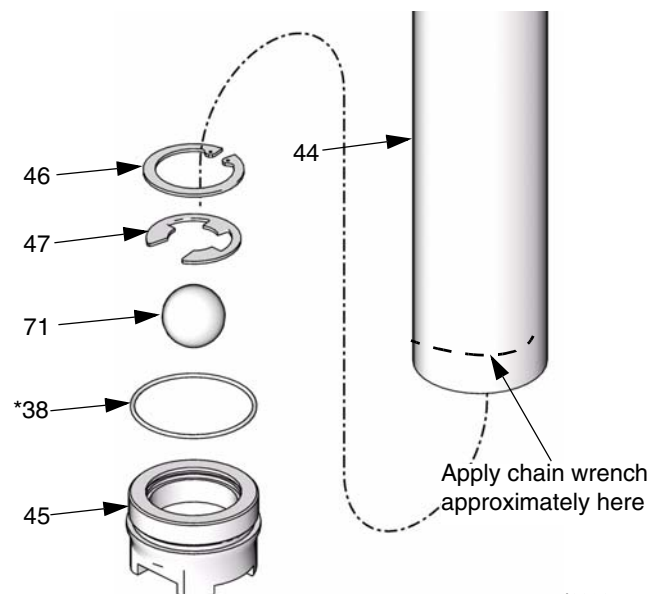
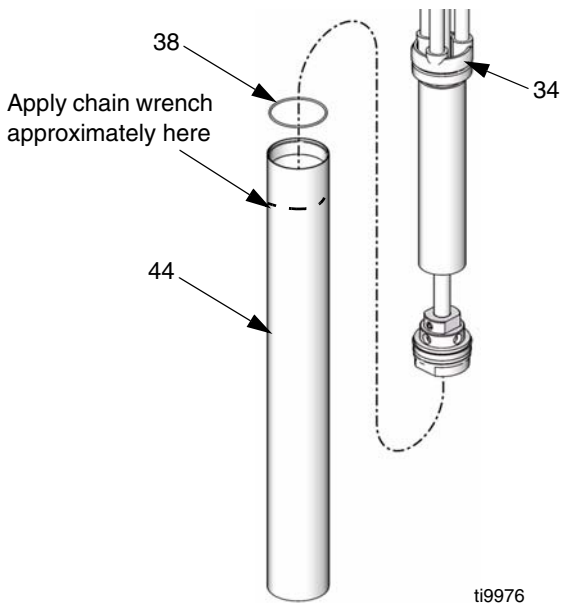

FIG. 17

2. With the foot valve still in place to support the suction tube, use a chain wrench near the bottom of the suction tube at the point indicated in FIG. 17, to loosen the suction tube (44) from the pump body (34).
3. Remove the foot valve assembly from the suction tube (44).
4. Remove retaining ring (46), snap ring (47), ball (71), and o-ring (38\*) from foot valve (45). Inspect all parts for damage. See FIG. 17.
5. Remove suction tube (44) from pump body (34). See FIG. 18.
6. Inspect o-ring (38) on pump body and suction tube for damage. See FIG. 18.



**FIG. 18**

7. Pull transfer shaft (20) out the bottom of pump body (34). See FIG. 19.

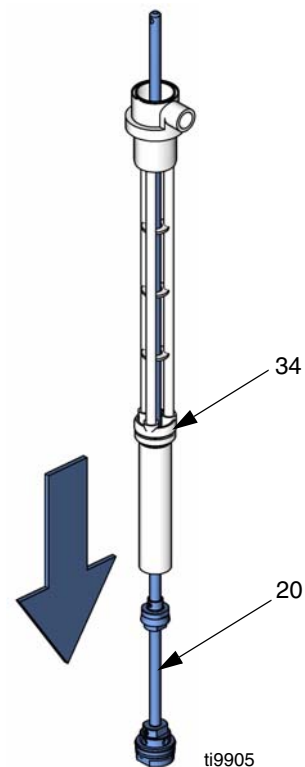

**FIG. 19**

8. Remove spring pin (56). Remove piston valve assembly. Unscrew piston valve (43) from piston housing (53). Remove wear ring (41\*), u-cup (40\*) and ball (42). Inspect all parts for damage. See FIG. 20.

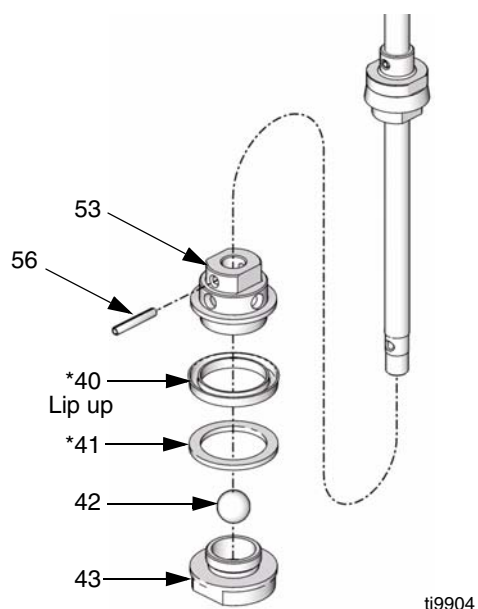

**FIG. 20**

- Remove spring pin (55) and slide upper fluid piston assembly down and off the transfer shaft (20). See FIG. 21.

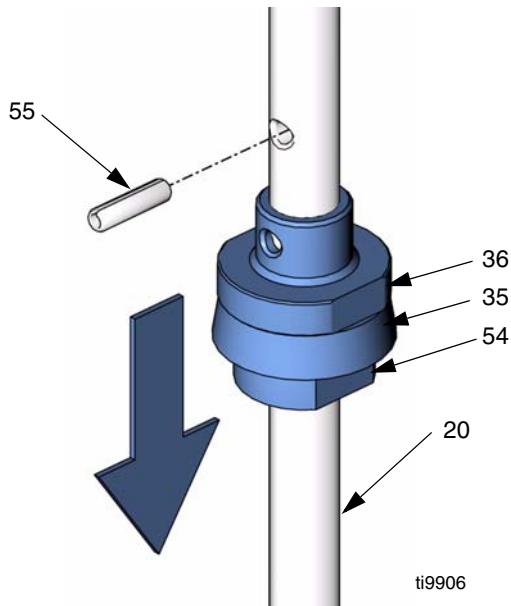

FIG. 21

- Unscrew mounting flange (26) from pump body (34). Remove o-ring (32\*) and PTFE gasket (33\*) from pump body (34). Inspect all parts for damage. See FIG. 23.

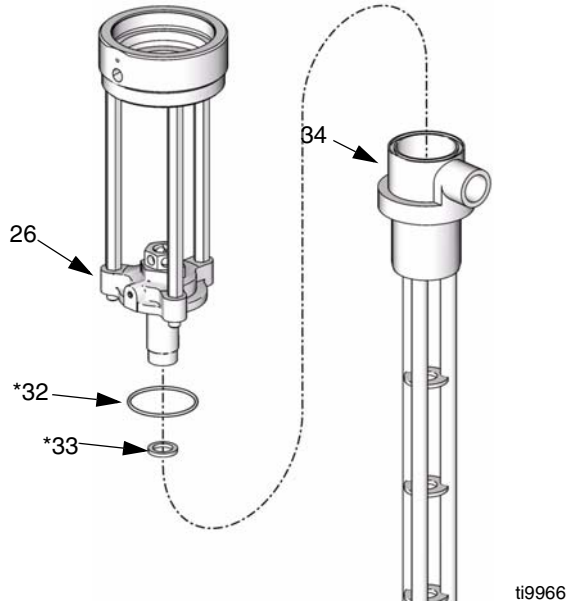

FIG. 23

- Loosen set screw (37) from collar (36). Remove collar from piston housing (54). Remove u-cup (35\*). Remove o-ring (57) from ID of piston housing. Inspect all parts for damage. See FIG. 22.

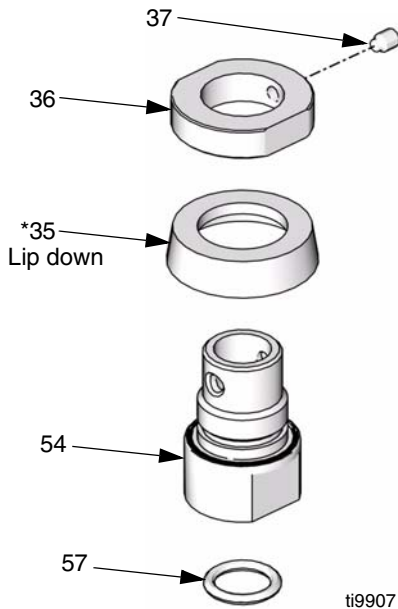

FIG. 22

- Remove hex nut (27) from mounting flange (26). Remove female gland (30\*), 2 PTFE packings (29\*), male gland (28\*) and wiper (31\*). Inspect all parts for damage. See FIG. 24.

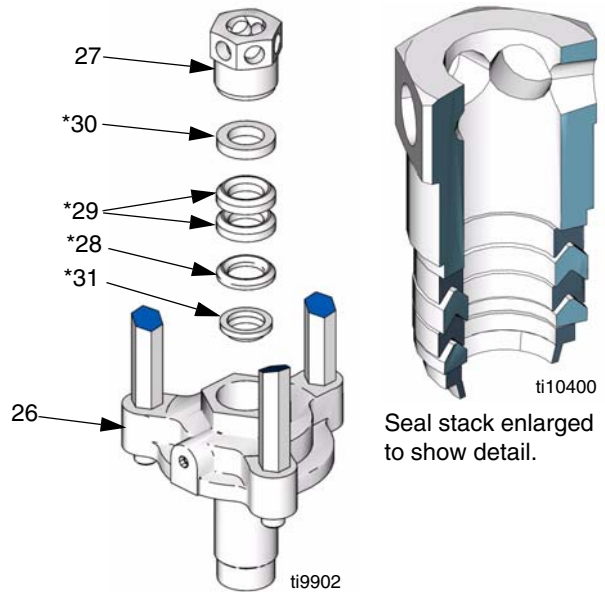



FIG. 24

## Reassembly

To reassemble the pump lower and air motor, reverse the steps on the preceding pages. Follow the torque requirements listed in the **Parts - Model 295616** drawing on page 16.

 See **Air Motor Repair**, step 2 and step 3 (FIG. 11 and FIG. 12) for special notes on reassembly.

## Troubleshooting

Problem	Cause	Solution
The pump fails to operate	Dirty or worn air motor.	Clean, service
	Inadequate air supply or restricted lines.	Clean lines or increase the air supply (see Technical Data).
	Closed or clogged air valves.	Open or clear the valves.
	Clogged fluid hose or valve.	Clear the hose or valves
	Worn or damaged valves or seals.	Service the valves or seals.
The pump operates, but the output is low on both strokes.	Clogged fluid hose or valve.	Clear the hose or valves.
	Exhausted fluid supply.	Refill the fluid supply and reprime the pump.
	Worn or damaged valves or seals.	Service the valves or seals.
The pump operates, but the output is low on the downstroke.	Held open or worn intake valve.	Clear or service the valve.
	Worn or damaged valves or seals.	Service the valves or seals.
The pump operates, but the output is low on the upstroke.	Held open or worn piston valve.	Clear or service the valve.
	Worn or damaged valves or seals.	Service the valves or seals.
Erratic or accelerated operation.	Exhausted fluid supply.	Refill the fluid supply and reprime the pump.
	Broken air motor compression spring.	Replace the spring.
Pump slowly moves after fluid shutoff in downstroke.	Clogged or dirty intake valve check ball.	Clean ball and seat.
	Worn or damaged valves or seats.	Install repair kit.
Pump slowly moves after fluid shutoff in upstroke.	Clogged or dirty lower piston ball or seat.	Clean ball and seat.
	Worn or damaged valves or seats.	Install repair kit.

# Parts - Model 295616

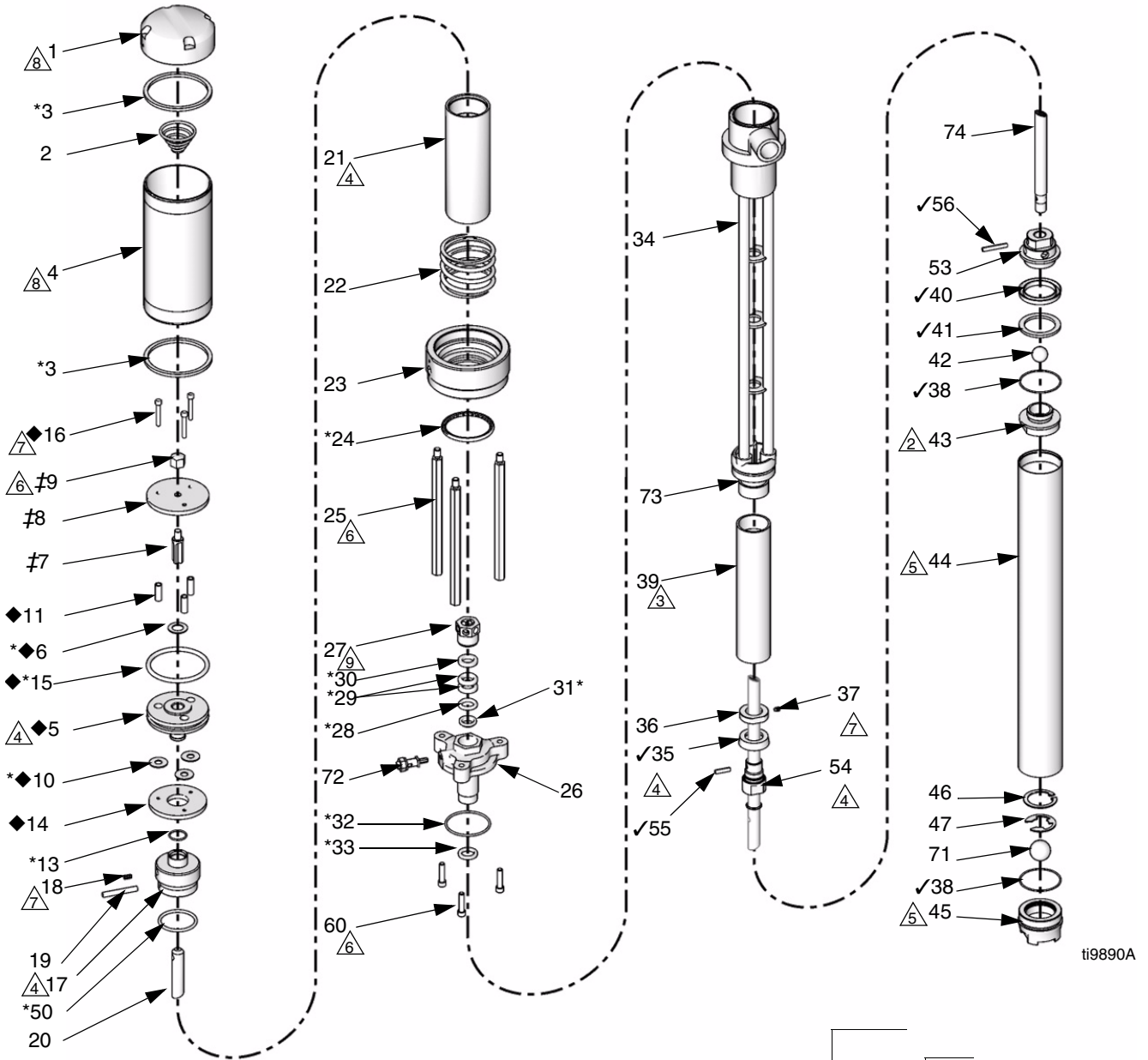

- △1 Lubricate all o-rings and seals before and after assembly
- △2 Torque to 45-55 ft-lbs (61-74.5 N•m)
- △3 Torque to 30-40 ft-lbs (40.6-54.2 N•m)
- △4 Torque to 15-20 ft-lbs (20.3-27.1 N•m)
- △5 Torque to 10-12 ft-lbs (13.5-16.3 N•m)
- △6 Torque to 110-120 in-lbs (12.3-13.4 N•m)
- △7 Torque to 20-30 in-lbs (2.2-3.3 N•m)
- △8 Torque to 50-60 in-lbs (5.6-6.7 N•m)
- △9 Tighten 1/8 to 1/4 turn past finger-tight

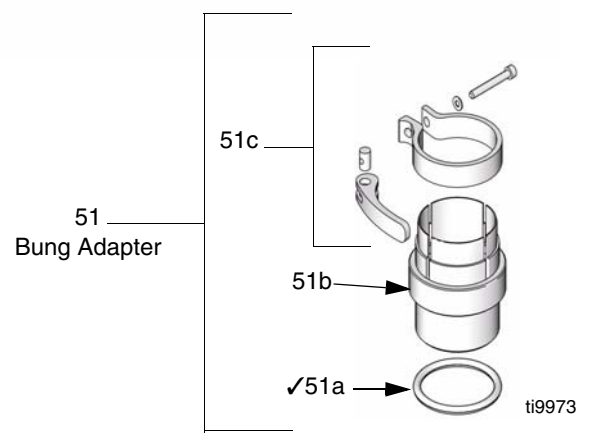

Ref	Part	Description	Qty	Ref	Part	Description	Qty
1	15J536	CAP, air cylinder	1	52†	114558	COUPLER, air line	1
2	157630	SPRING, tapered	1	53	15J570	HOUSING, piston	1
3*		PACKING, square	2	54*		PISTON, upper	1
4	15J537	CYLINDER, air motor	1	55✓*		PIN, spring, 3/16 x 3/4	2
5◆	15J538	HEAD, air piston	1	56✓		PIN, spring, 3/16 x 1 1/4	1
6*◆		GASKET, upper	1	57✓		O-RING	1
7‡	15J540	GUIDE, valve	1	60	120348	SCREW, cap, socket head 1/4-20 x 1 in. (25 mm)	3
8‡	15J541	DISK, valve	1	69†	15H197	TOOL, spanner wrench	2
9‡	15J542	CAP, valve guide	1	70†	15K008	LABEL, material identification.	1
10*◆		GASKET, lower	3	71	107167	BALL, intake, sst, 1 in. (25 mm)	1
11◆	15J544	SPACER, disk	3	72	116343	SCREW, ground	1
13*		O-RING	1	73✓		O-RING	1
14◆	15J546	DISK, air piston	1	74	15U574	SHAFT, transfer, lower	1
15*◆		O-RING	1				
16◆	121610	SCREW, cap, socket head, 10-32 x 1 3/8 in. (35mm)	3				
17	15J547	CAP, air piston	1				
18	102387	SCREW, set, socket head, 10-32 x 3/8 in. (10 mm)	1				
19	15J548	PIN, dowel	1				
20*		SHAFT, transfer	1				
21	288338	PISTON, air	1				
22	15J551	SPRING, compression	1				
23	15J552	BASE, air motor	1				
24*		O-RING	1				
25	15J553	ROD, tie	3				
26	15J554	FLANGE, mounting	1				
27	15J555	NUT, hex	1				
28*		GLAND, packing, (male)	1				
29*		V-PACKING, PTFE	2				
30*		GLAND, packing, (female)	1				
31*		WIPER, ROD	1				
32*		O-RING, PTFE, encapsulated	1				
33*		GASKET, PTFE	1				
34	288339	BODY, pump, 2:1	1				
35✓		PACKING, piston cup	1				
36	15J563	COLLAR, retaining	1				
37	101194	SCREW, set, socket head, 10-32 x .25 in. (6 mm)	1				
38✓		O-RING	2				
39	15J564	CYLINDER, pressure pump	1				
40✓		PACKING, u-cup, PTFE	1				
41✓		RING, wear	1				
42	103462	BALL, outlet, sst, 3/4 in. (19 mm)	1				
43	15J567	VALVE, piston	1				
44	15J568	TUBE, suction	1				
45	15J569	VALVE	1				
46	120734	RING, retaining, internal	1				
47	120735	RING, snap, e series	1				
48†	206264	VALVE, needle	1				
49†	169969	FITTING, air line	1				
50*		O-RING	1				
51	253146	ADAPTER, bung (includes 51a-51g)	1				
51a✓	120998	O-RING, fluoroelastomer	1				
51b	15H196	ADAPTER	1				
51c	234188	CLAMP, hopper	1				
51h✓†	120207	O-RING	1				

\* Parts included in Upper Seal Repair Kit 247882 (not sold separately).

✓ Parts included in Lower Seal Repair Kit 247883.

NOTE: Seal Repair Kit 258003 includes all parts in kit 247882 and kit 247883.

‡ Parts included in repair kit 261053

◆ Parts included in repair kit 261056

\* Parts included in repair kit 256560

† Indicates parts not shown, 48, 49, 51h, 52, 69, 70 (shipped loose)

# Parts - Model 261058

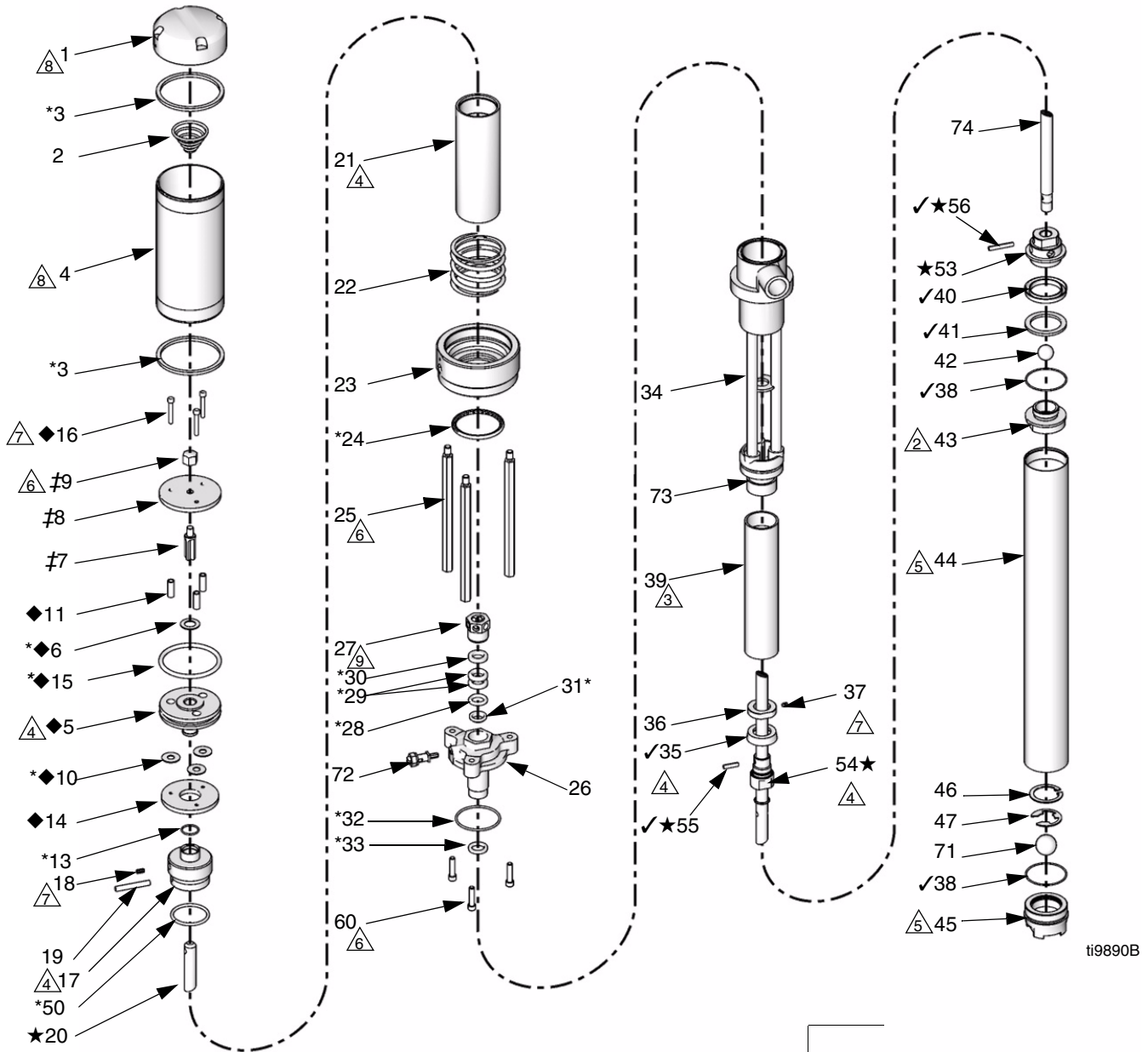

- ⚠ Lubricate all o-rings and seals before and after assembly
- ⚡ Torque to 45-55 ft-lbs (61-74.5 N•m)
- ⚡ Torque to 30-40 ft-lbs (40.6-54.2 N•m)
- ⚡ Torque to 15-20 ft-lbs (20.3-27.1 N•m)
- ⚡ Torque to 10-12 ft-lbs (13.5-16.3 N•m)
- ⚡ Torque to 110-120 in-lbs (12.3-13.4 N•m)
- ⚡ Torque to 20-30 in-lbs (2.2-3.3 N•m)
- ⚡ Torque to 50-60 in-lbs (5.6-6.7 N•m)
- ⚡ Tighten 1/8 to 1/4 turn past finger-tight

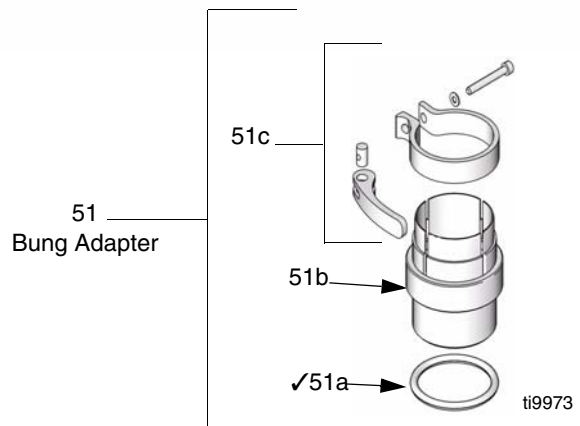

Ref	Part	Description	Qty	Ref	Part	Description	Qty
1	15J536	CAP, air cylinder	1	52†	114558	COUPLER, air line	1
2	157630	SPRING, tapered	1	53★	15J570	HOUSING, piston	1
3*		PACKING, square	2	54★	15U575	PISTON, upper	1
4	15J537	CYLINDER, air motor	1	55✓★		PIN, spring, 3/16 x 3/4	1
5◆	15J538	HEAD, air piston	1	56✓★		PIN, spring, 3/16 x 1 1/4	1
6*◆		GASKET, upper	1	57✓★		O-RING	1
7‡	15J540	GUIDE, valve	1	60	120348	SCREW, cap, socket head 1/4-20 x 1 in. (25 mm)	3
8‡	15J541	DISK, valve	1	69†	15H197	TOOL, spanner wrench	2
9‡	15J542	CAP, valve guide	1	70†	15K008	LABEL, material identification.	1
10*◆		GASKET, lower	3	71	107167	BALL, intake, sst, 1 in. (25 mm)	1
11◆	15J544	SPACER, disk	3	72	116343	SCREW, ground	1
13*		O-RING	1	73	113944	O-RING	1
14◆	15J546	DISK, air piston	1	74	15U574	SHAFT, transfer, lower	1
15*◆		O-RING	1				
16◆	121610	SCREW, cap, socket head, 10-32 x 1 3/8 in. (35mm)	3				
17	15J547	CAP, air piston	1				
18	102387	SCREW, set, socket head, 10-32 x 3/8 in. (10 mm)	1				
19	15J548	PIN, dowel	1				
20★	15U573	SHAFT, transfer	1				
21	288338	PISTON, air	1				
22	15J551	SPRING, compression	1				
23	15J552	BASE, air motor	1				
24*		O-RING	1				
25	15J553	ROD, tie	3				
26	15J554	FLANGE, mounting	1				
27	15J555	NUT, hex	1				
28*		GLAND, packing, (male)	1				
29*		V-PACKING, PTFE	2				
30*		GLAND, packing, (female)	1				
31*		WIPER, ROD	1				
32*		O-RING, PTFE, encapsulated	1				
33*		GASKET, PTFE	1				
34	260865	BODY, pump, 2:1	1				
35✓		PACKING, piston cup	1				
36	15U693	COLLAR, retaining	1				
37	101194	SCREW, set, socket head, 10-32 x .25 in. (6 mm)	1				
38✓		O-RING	2				
39	15J564	CYLINDER, pressure pump	1				
40✓		PACKING, u-cup, PTFE	1				
41✓		RING, wear	1				
42	103462	BALL, outlet, sst, 3/4 in. (19 mm)	1				
43	15J567	VALVE, piston	1				
44	15J568	TUBE, suction	1				
45	15J569	VALVE	1				
46	120734	RING, retaining, internal	1				
47	120735	RING, snap, e series	1				
48†	206264	VALVE, needle	1				
49†	169969	FITTING, air line	1				
50*		O-RING	1				
51	253146	ADAPTER, bung (includes 51a-51g)	1				
51a✓	120998	O-RING, fluoroelastomer	1				
51b	15H196	ADAPTER	1				
51c	234188	CLAMP, hopper	1				
51h†✓	120207	O-RING	1				

\* Parts included in Upper Seal Repair Kit 247882  
(not sold separately).

✓ Parts included in Lower Seal Repair Kit 247883.  
Note: Seal Repair Kit 258003 includes all parts in kit  
247882 and kit 247883.

‡ Parts included in repair kit 261053

◆ Parts included in repair kit 261056

★ Parts included in repair kit 260754

† Indicates parts not shown, 48, 49, 51h, 52, 69, 70  
(shipped loose)

# Technical Data

Pressure Ratio . . . . .	2.25:1
Max fluid working pressure . . . . .	405 psi (2.8 MPa, 28 bar)
Maximum Air inlet pressure . . . . .	180 psi (1.2 MPa, 12 bar)
Max Output Flow (continuous) . . . . .	5.0 GPM (20 lpm)
Max Output Flow (intermittent . . . . .	7.5 GPM (28 lpm)
Pump cycles per 1 gallon (3.8 liters) . . . . .	15.9
Maximum recommended pump speed for continuous operation . . . . .	100 cycles per min (150 cycles per min intermittent)
Gallons (liters) per pump cycle . . . . .	0.063 (.24)
Air consumption . . . . .	See performance chart
Maximum Ambient temperature . . . . .	120° F (50° C)
Maximum Fluid Temperature . . . . .	190° F (88° C)
Maximum operating temperature of fluid pump . . . . .	480° F (248° C) for non-hazardous location applications only (runaway)
Maximum operating temperature of air motor . . . . .	280° F (138° C) for non-hazardous location applications only (runaway)
Wetted parts . . . . .	Stainless Steel, PTFE
Air Inlet Port . . . . .	1/4 npt(f)
Fluid Outlet Port . . . . .	3/4 npt(f)
Weight . . . . .	21.0 lb (9.5 kg)
Sound Pressure . . . . .	88.7 dB(A) at 80 psi (.55 MPa, 5.5 bar)
Sound Power, per ISO 9614-2 . . . . .	96.8 dB(A) at 80 psi (.55 MPa, 5.5 bar)

# Dimensions

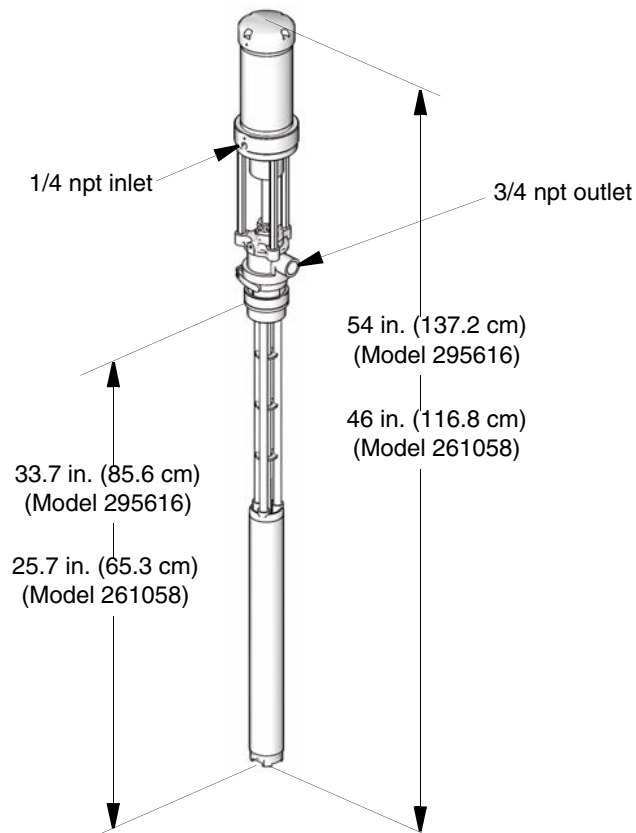

ti9889a

# Performance Chart

## Calculate Fluid Outlet Pressure (black curves)

To calculate fluid outlet pressure (MPa/bar/psi) at a specific fluid flow (lpm/gpm) and operating air pressure (MPa/bar/psi), use the following instructions and pump data chart.

1. Locate desired fluid flow along bottom of chart.
2. Follow vertical line up to intersection with selected air pressure curve (black). Follow horizontally left to read fluid outlet pressure.

## Calculate Pump Air Consumption (gray curves)

To calculate pump air consumption (m<sup>3</sup>/min or scfm) at a specific fluid flow (lpm/gpm) and air pressure (MPa/bar/psi), use the following instructions and pump data chart.

1. Locate desired fluid flow along bottom of chart.
2. Follow vertical line up to intersection with selected air pressure curve (gray). Follow horizontally right to read air consumption.

### Key: Air Pressure

- A 180 psi (1.2 MPa, 12.4 bar)
- B 100 psi (0.7 MPa, 7 bar)
- C 70 psi (0.5 MPa, 7.8 bar)
- D 40 psi (0.3 MPa, 2.8 bar)

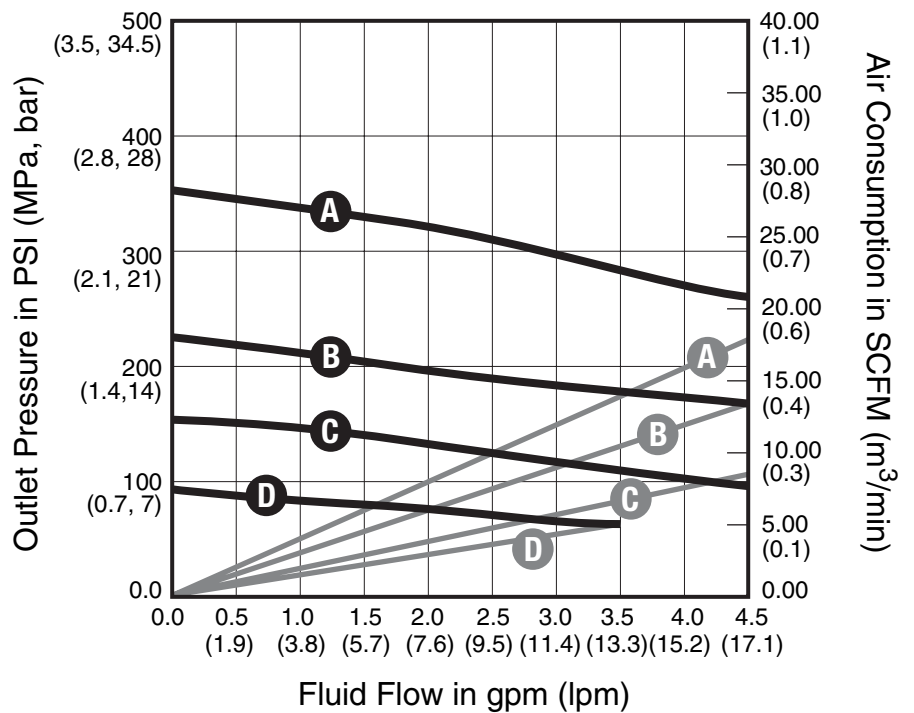

(This chart applies to Model 295616 only.)

# Graco Standard Warranty

Graco warrants all equipment referenced in this document which is manufactured by Graco and bearing its name to be free from defects in material and workmanship on the date of sale to the original purchaser for use. With the exception of any special, extended, or limited warranty published by Graco, Graco will, for a period of twelve months from the date of sale, repair or replace any part of the equipment determined by Graco to be defective. This warranty applies only when the equipment is installed, operated and maintained in accordance with Graco's written recommendations.

This warranty does not cover, and Graco shall not be liable for general wear and tear, or any malfunction, damage or wear caused by faulty installation, misapplication, abrasion, corrosion, inadequate or improper maintenance, negligence, accident, tampering, or substitution of non-Graco component parts. Nor shall Graco be liable for malfunction, damage or wear caused by the incompatibility of Graco equipment with structures, accessories, equipment or materials not supplied by Graco, or the improper design, manufacture, installation, operation or maintenance of structures, accessories, equipment or materials not supplied by Graco.

This warranty is conditioned upon the prepaid return of the equipment claimed to be defective to an authorized Graco distributor for verification of the claimed defect. If the claimed defect is verified, Graco will repair or replace free of charge any defective parts. The equipment will be returned to the original purchaser transportation prepaid. If inspection of the equipment does not disclose any defect in material or workmanship, repairs will be made at a reasonable charge, which charges may include the costs of parts, labor, and transportation.

**THIS WARRANTY IS EXCLUSIVE, AND IS IN LIEU OF ANY OTHER WARRANTIES, EXPRESS OR IMPLIED, INCLUDING BUT NOT LIMITED TO WARRANTY OF MERCHANTABILITY OR WARRANTY OF FITNESS FOR A PARTICULAR PURPOSE.**

Graco's sole obligation and buyer's sole remedy for any breach of warranty shall be as set forth above. The buyer agrees that no other remedy (including, but not limited to, incidental or consequential damages for lost profits, lost sales, injury to person or property, or any other incidental or consequential loss) shall be available. Any action for breach of warranty must be brought within two (2) years of the date of sale.

**GRACO MAKES NO WARRANTY, AND DISCLAIMS ALL IMPLIED WARRANTIES OF MERCHANTABILITY AND FITNESS FOR A PARTICULAR PURPOSE, IN CONNECTION WITH ACCESSORIES, EQUIPMENT, MATERIALS OR COMPONENTS SOLD BUT NOT MANUFACTURED BY GRACO.** These items sold, but not manufactured by Graco (such as electric motors, switches, hose, etc.), are subject to the warranty, if any, of their manufacturer. Graco will provide purchaser with reasonable assistance in making any claim for breach of these warranties.

In no event will Graco be liable for indirect, incidental, special or consequential damages resulting from Graco supplying equipment hereunder, or the furnishing, performance, or use of any products or other goods sold hereto, whether due to a breach of contract, breach of warranty, the negligence of Graco, or otherwise.

## **FOR GRACO CANADA CUSTOMERS**

The Parties acknowledge that they have required that the present document, as well as all documents, notices and legal proceedings entered into, given or instituted pursuant hereto or relating directly or indirectly hereto, be drawn up in English. Les parties reconnaissent avoir convenu que la rédaction du présente document sera en Anglais, ainsi que tous documents, avis et procédures judiciaires exécutés, donnés ou intentés, à la suite de ou en rapport, directement ou indirectement, avec les procédures concernées.

# Graco Information

**TO PLACE AN ORDER**, contact your Graco distributor or call to identify the nearest distributor.

**Phone:** 612-623-6921 **or Toll Free:** 1-800-328-0211 **Fax:** 612-378-3505

*All written and visual data contained in this document reflects the latest product information available at the time of publication.  
Graco reserves the right to make changes at any time without notice.*

*This manual contains English. MM 311882*

**Graco Headquarters:** Minneapolis  
**International Offices:** Belgium, China, Japan, Korea

**GRACO INC. P.O. BOX 1441 MINNEAPOLIS, MN 55440-1441**

Copyright 2007, Graco Inc. is registered to I.S. EN ISO 9001

www.graco.com  
Revised 6/2008